



RM699B

miniature relays

Version (V)

Version (H)



- Cover width only 5,0 mm
- Sealed for soldering and cleaning
- **Terminals arrangement: vertical version (V) and horizontal version (H)**
- Applications: for PLC's, industrial machinery, time relays, counters, temperature adjusters, measurement instruments, office equipment, etc.
- Recognitions, certifications, directives: RoHS,   

Contact data

Number and type of contacts	1 CO, 1 NO	
Contact material	AgSnO₂, AgNi	AgSnO ₂ /Au hard gold plating ❶ AgNi/Au hard gold plating ❶
Max. switching voltage	400 V AC / 250 V DC	
Min. switching voltage	10 V	
Rated load	AC1 DC1	6 A / 250 V AC 6 A / 30 V DC; 0,15 A / 250 V DC
Motor load	AC3 acc. to IEC 60947-4-1	0,186 kW 250 V AC, single-phase motor
Min. switching current	100 mA	
Max. inrush current	10 A 20 ms	
Rated current	6 A	
Max. breaking capacity	AC1	1 500 VA
Min. breaking capacity	1 W	
Contact resistance	≤ 100 mΩ 100 mA, 24 V	
Max. operating frequency	AC1	360 cycles/hour
• at rated load • no load		72 000 cycles/hour
Coil data		
Rated voltage	DC	5, 6, 9, 12, 24, 48, 60 V
Must release voltage	DC: ≥ 0,05 U _n	
Operating range of supply voltage	see Table 1	
Rated power consumption	DC	0,17 W 5... 24 V 0,21 W 48, 60 V
Insulation according to EN 60664-1		
Insulation rated voltage	250 V AC	
Rated surge voltage	6 000 V 1,2 / 50 μs	
Overvoltage category	III	
Dielectric strength	4 000 V AC type of insulation: reinforced	
• between coil and contacts • contact clearance	1 000 V AC type of clearance: micro-disconnection	
Contact - coil distance	≥ 6 mm	
• clearance • creepage	≥ 8 mm	
General data		
Operating / release time (typical values)	8 ms / 4 ms	
Electrical life (number of cycles)	the NO and NC contact loaded (bilateral load): see Fig. 1 the NO contact loaded: > 3 x 10 ⁴ 6 A, 250 V AC	
• resistive AC1	6 x 10 ³ 186 W (single-phase motor), AgNi	
• inductive AC3		
Mechanical life (cycles)	> 10 ⁷	
Dimensions (L x W x H)	28 x 5 x 15 mm	
Weight	6 g	
Ambient temperature	• storage (non-condensation and/or icing)	-40...+85 °C
	• operating	-40...+85 °C
Cover protection category	IP 67 EN 60529	
Environmental protection	RTIII EN 61810-7	
Relative humidity	5...85%	
Shock resistance	5 g	
Vibration resistance	5 g 10...55 Hz	
Solder bath temperature	max. 260 °C	
Soldering time	max. 5 s	

The data in bold type relate to the standard versions of the relays. ❶ For gold-plated contacts - when the maximum values given have been exceeded, the gold layer is destroyed. Then, the advantages of gold-plating disappear and the values are as for AgSnO₂, AgNi contacts (see beside), and electrical life of these contacts may be shorter than of normal contacts.

RM699B

miniature relays

Dimensions

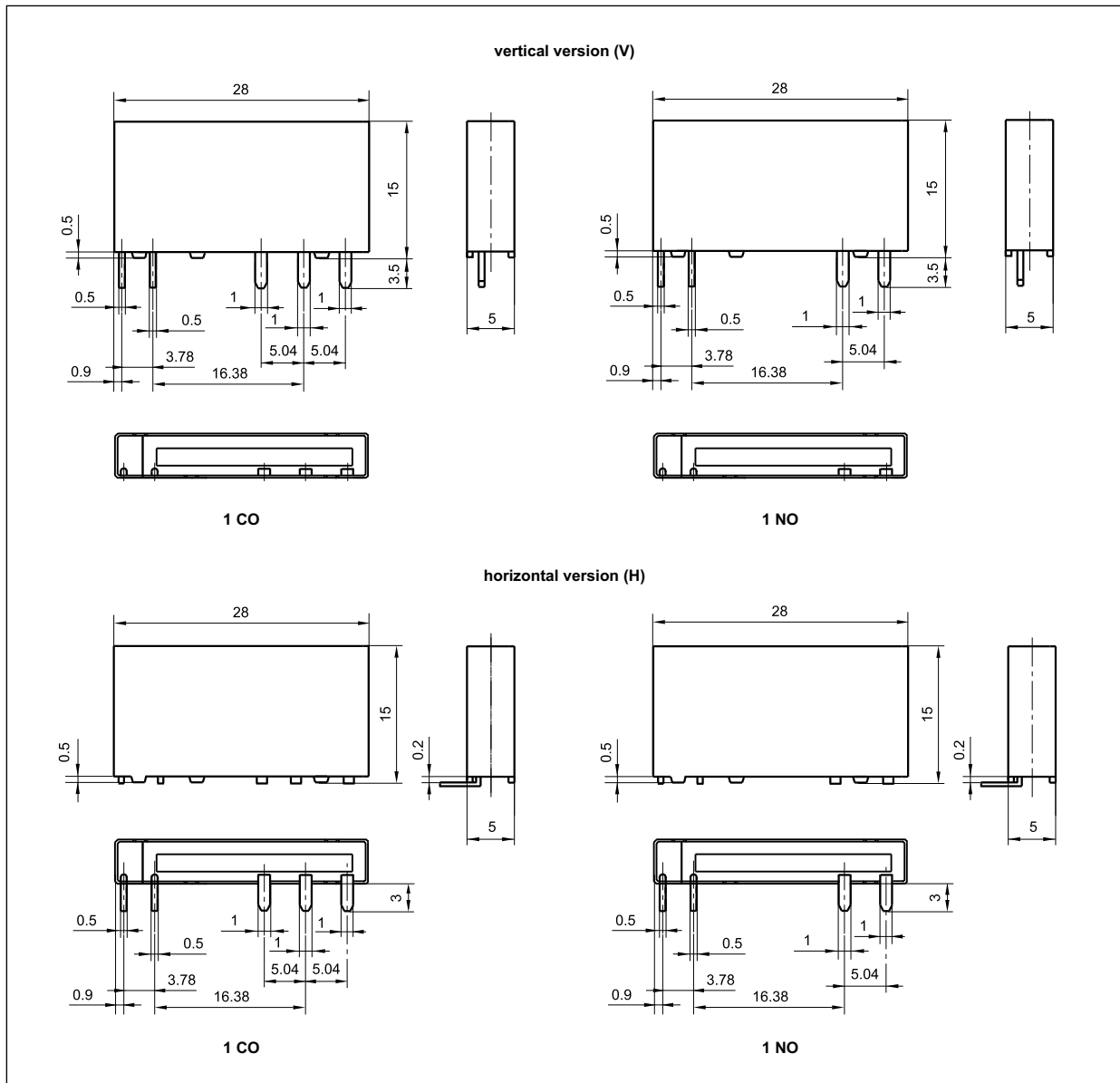

Mounting

Relays **RM699B vertical version (V)** are designed for:

- direct PCB mounting
- sockets **PI6W-1P**, 35 mm rail mount acc. to EN 60715 (see page 6).

Relays **RM699B horizontal version (H)** are designed for direct PCB mounting.

PI6W-1P

Plug-in sockets
for relays
RM699BV
or RSR30



Connection diagrams (pin side view)

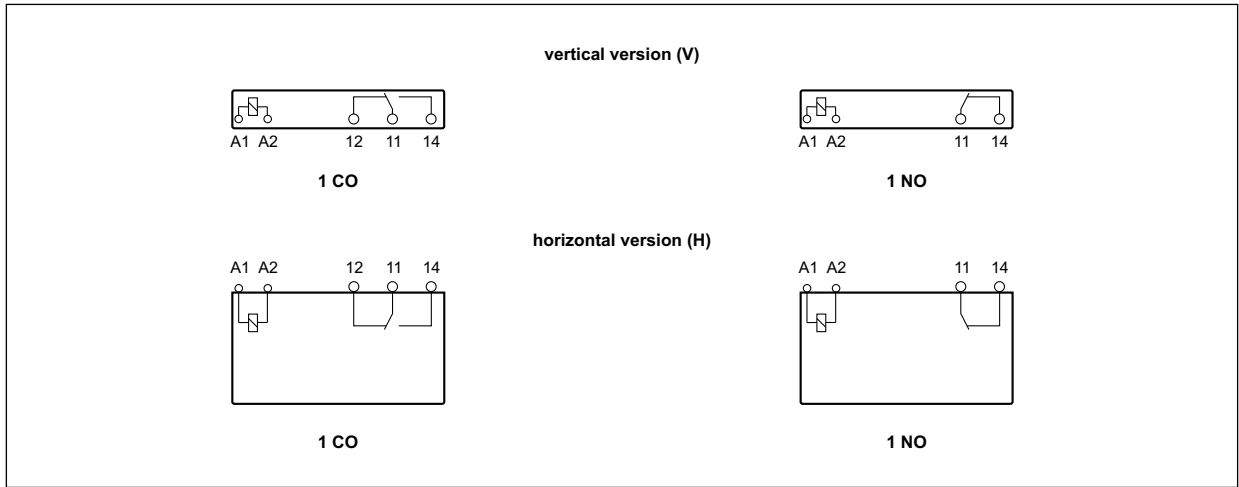

Pinout (solder side view)

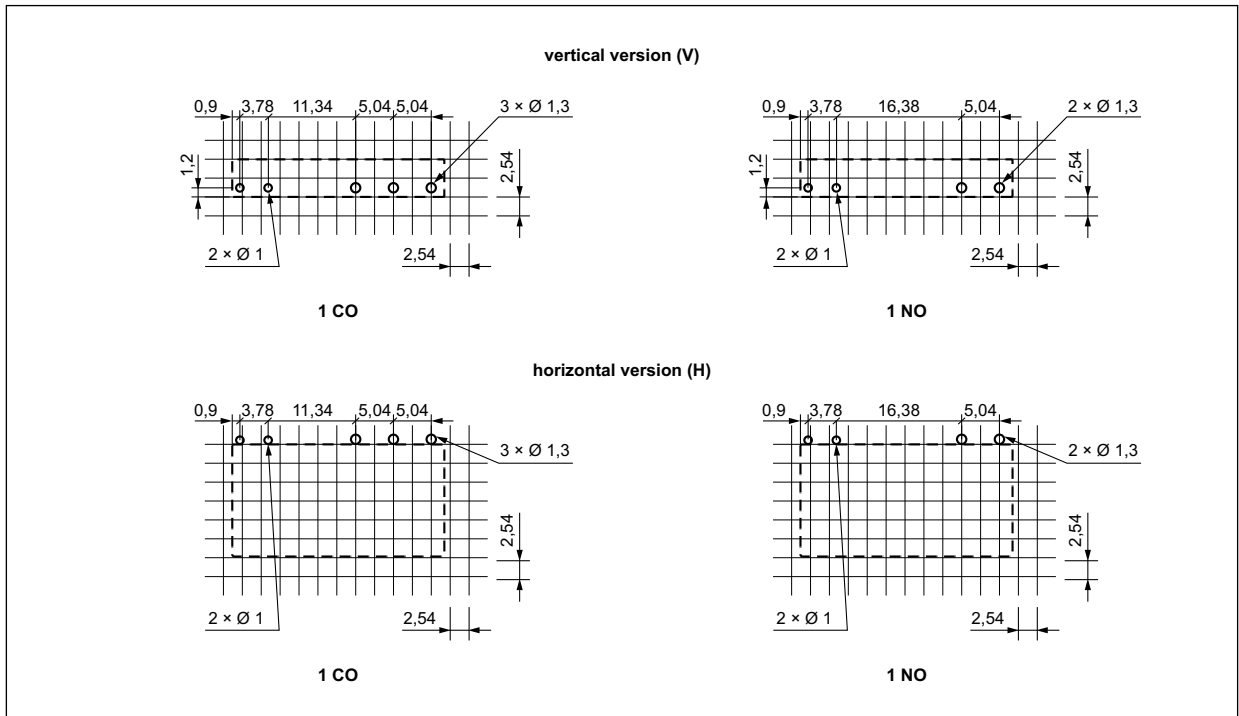

Electrical life at AC resistive current. Fig. 1
Switching frequency: 360 cycles/hour

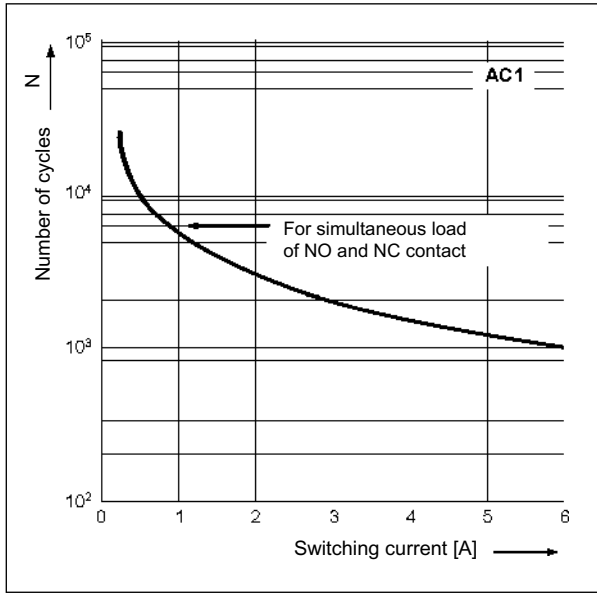

Max. DC resistive load breaking capacity Fig. 2

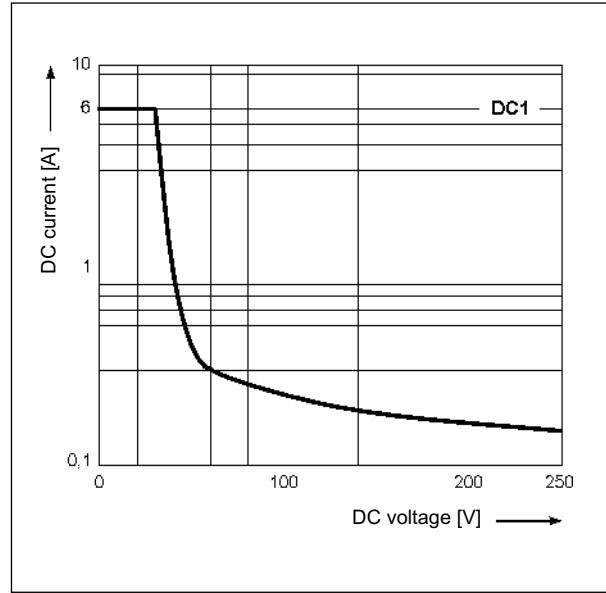

Coil operating range - DC Fig. 3

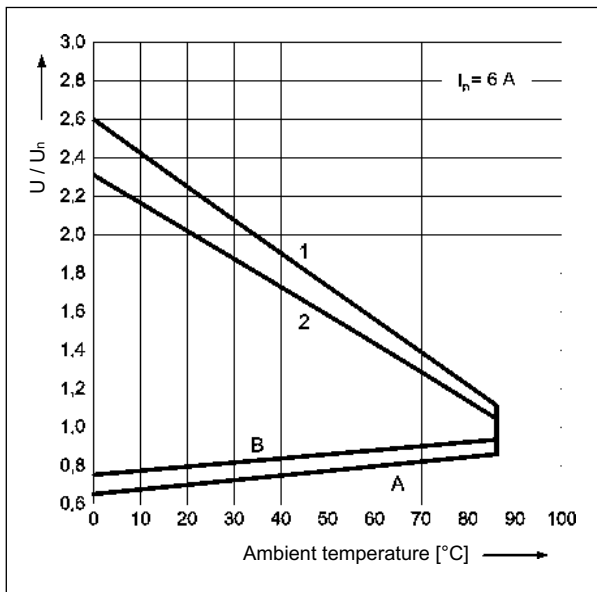

Description of Fig. 3

A - relations between make voltage and ambient temperature at no load on contacts. Coil temperature and ambient temperature are equal before coil energizing. Make voltage is not higher than the value read on Y axis (multiplication of rated voltage).

B - relations between make voltage and ambient temperature after initial coil heating up with $1,1 U_n$, at continues load of I_n on contacts. Make voltage is not higher than the value read on Y axis (multiplication of rated voltage).

1, 2 - values on Y axis represent allowed overvoltage on coil at certain ambient temperature and contact load:

- 1 - no load
- 2 - rated load

RM699B

miniature relays

Coil data - DC voltage version

Table 1

Coil code		Coil resistance at 20 °C Ω	Acceptable resistance	Coil operating range V DC	
				min. (at 20 °C)	max. (at 20 °C)
1005	5	147	± 10%	3,75	7,5
1006	6	212	± 10%	4,5	9,0
1009	9	476	± 10%	6,75	13,0
1012	12	848	± 10%	9,0	18,0
1024	24	3 390	± 15%	18,0	36,0
1048	48	10 600	± 15%	36,0	72,0
1060	60	16 600	± 15%	45,0	90,0

Ordering codes

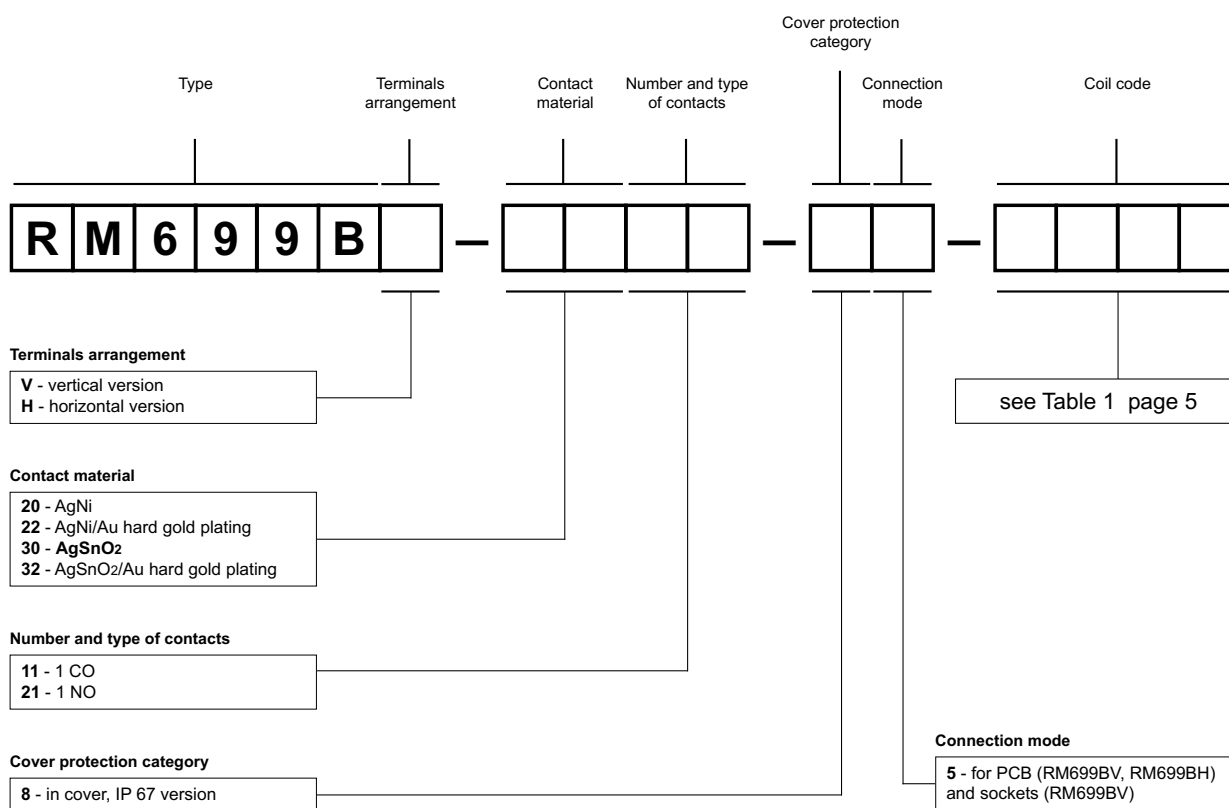

Examples of ordering code:

RM699BV-3011-85-1012

relay **RM699B**, vertical version, for PCB and sockets, one changeover contact, contact material AgSnO₂, coil voltage 12 V DC, in cover IP 67

RM699BH-2021-85-1005

relay **RM699B**, horizontal version, for PCB, one normally open contact, contact material AgNi, coil voltage 5 V DC, in cover IP 67

PI6W-1P

socket 6,2 mm



- Width 6,2 mm • Socket **PI6W-1P** without electronic
- Co-operate with relays: electromagnetic **RM699BV** or solid state **RSR30** ⓘ
- The input voltage complies with the voltage of the operational relay applied
- 35 mm rail mount acc. to EN 60715
- May be linked with interconnection strip type **ZG20**
- Accessories: description plates **PI6W-1246**
- Recognitions, certifications, directives: RoHS,

Output circuit

Number and type of contacts / outputs	RM699BV: 1 CO	RSR30: 1 NO ⓘ
Max. voltage	400 V AC / 250 V DC	
Max. load	AC1	6 A / 250 V AC
Rated current	6 A	
Insulation according to EN 60664-1		
Insulation rated voltage	250 V AC	
Rated surge voltage	4 000 V 1,2 / 50 µs	
Overvoltage category	III	
Insulation pollution degree	3	
Dielectric strength	• input - output	4 000 V AC 50/60 Hz, 1 min., type of insulation: reinforced
	• input - output	6 000 V 1,2 / 50 µs
Input - output distance	≥ 6 mm / ≥ 8 mm	
• clearance / creepage		
General data		
Dimensions (L x W x H)	98,5 x 6,2 x 85,5 mm	
Weight	40 g	
Ambient temperature (non-condensation and/or icing)	• storage	-40...+70 °C
	• operating	-40...+55 °C -40...+60 °C 12, 24 V DC
Protection category	IP 20	EN 60529
Environmental protection	RTI	EN 61810-7

Connection diagram

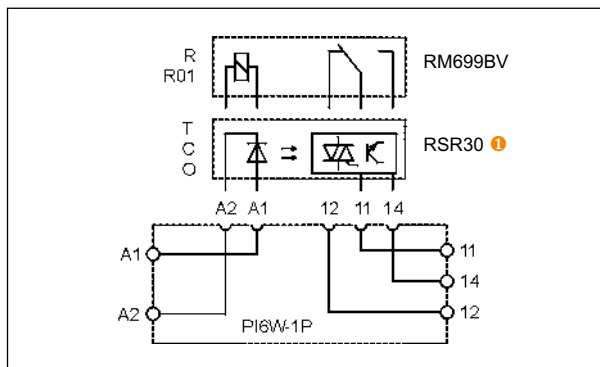

ⓘ Solid state relays type **RSR30** - see www.repol.com.pl

Ordering codes

Ordering codes: **PI6W-1P**.

Mounting

Sockets **PI6W-1P** are designed for direct mounting on 35 mm rail mount acc. to EN 60715. **Connections:** max. cross section of the cables: 1 x 2,5 mm² / 2 x 1,5 mm² (1 x 14 / 2 x 16 AWG), stripping length: 9 mm, max. tightening moment for the terminal: 0,3 Nm. **PI6W-1P** may be linked with interconnection strip type **ZG20**. Description plates of **PI6W-1246** type are offered for **PI6W-1P** sockets.

PRECAUTIONS:

1. Ensure that the parameters of the product described in its specification provide a safety margin for the appropriate operation of the device or system and never use the product in circumstances which exceed the parameters of the product. 2. Never touch any live parts of the device. 3. Ensure that the product has been connected correctly. An incorrect connection may cause malfunction, excessive heating or risk of fire. 4. In case of any risk of any serious material loss or death or injuries of humans or animals, the devices or systems shall be designed so to equip them with double safety system to guarantee their reliable operation.

Dimensions

