

Surface Mount Miniature Trimmers Multiturn Cermet Sealed



The TSM4 trimming potentiometer has been designed for surface mount applications and offers volumetric efficiency $5 \times 5 \times 3.7 \text{ mm}^3$ with high performance and stability.

The TSM4 design is suitable for both manual or automatic operation, and can withstand vapor phase and reflow soldering techniques.

FEATURES

- 0.25 Watt at 85°C
- Professional grade
- Excellent stability
- Wide ohmic range
- Low contact resistance variation
- Small size for optimum packing density
- Suitable for both manual or automatic operation

DIMENSIONS in millimeters

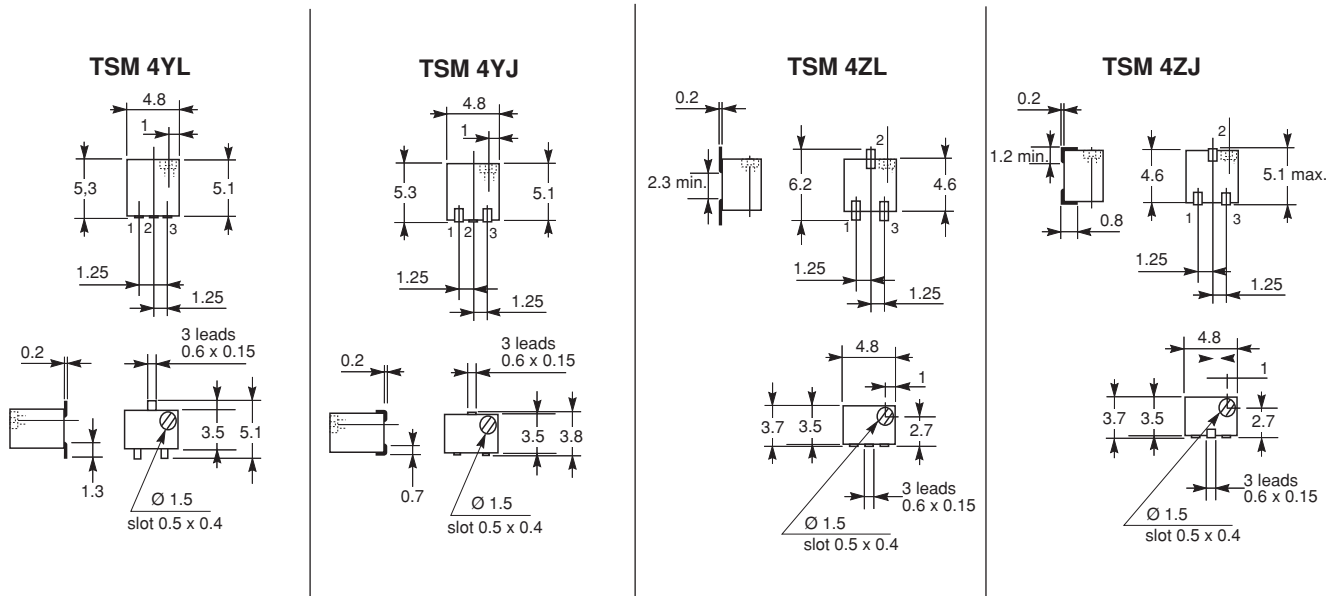

RECOMMENDED SOLDERING AREAS

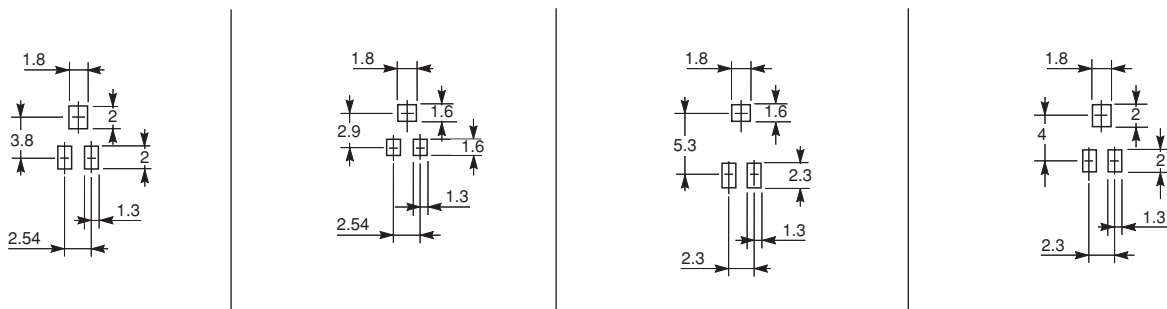

CIRCUIT DIAGRAM

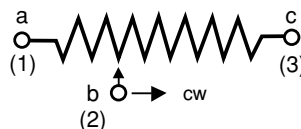



ELECTRICAL SPECIFICATIONS		
Resistive Element		Cermet
Electrical Travel		11 turns ± 2
Resistance Range		10Ω to 1MΩ
Standard Series		1 - 2 - 5
Tolerance Standard		±10%
Power Rating	Linear	0.25W at + 85°C
	Logarithmic	not applicable
Temperature Coefficient		See Standard Resistance Element Table
Limiting Element Voltage (Linear Law)		200V
Contact Resistance Variation		1% or 3Ω
End Resistance (Typical)		1Ω
Dielectric Strength (RMS)		600V
Insulation Resistance		10 ⁶ MΩ

MECHANICAL SPECIFICATIONS

Mechanical Travel	13 turns ± 2
Operating Torque (max. Ncm)	1
End Stop Torque (Ncm)	clutch action
Unit Weight (max. g.)	0.15

ENVIRONMENTAL SPECIFICATIONS

Temperature Range	- 55°C + 125°C
Climatic Category	55 / 125 / 56
Sealing	sealed container solder immersion IP67

POWER RATING CHART

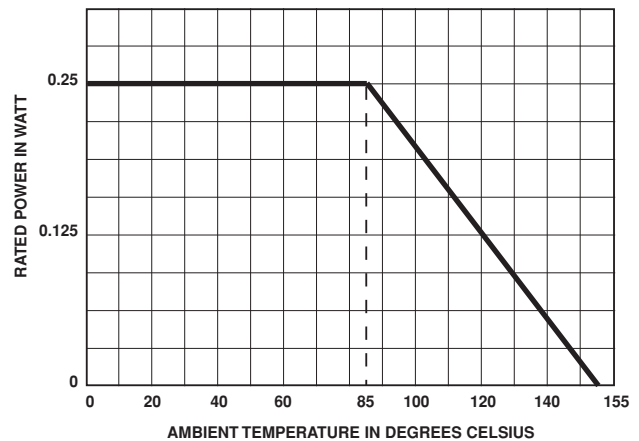

PERFORMANCE			
TESTS	CONDITIONS	TYPICAL VALUES AND DRIFTS	
		$\frac{\Delta RT}{RT}$ (%)	$\frac{\Delta R_{1-2}}{R_{1-2}}$ (%)
Load Life	1000 hours at rated power 90'/30' - ambient temperature + 85°C	± 2% Contact resistance variation : $\Delta > 1\% R_n$	± 3 %
Moisture Resistance	MIL STD 202 Method 106 10 cycles of 24 hours constituted with damp heat - cold - vibrations	± 2 % Dielectric strength : 1000 V _{RMS} Insulation resistance : $> 10^4 M\Omega$	± 3 %
Long Term Damp Heat	Temperature 40°C - RH 93% 56 days	± 2 % Dielectric strength : 1000 V _{RMS} Insulation resistance : $> 10^4 M\Omega$	± 3 %
Thermal Shock	- 55°C to + 125°C - 5 cycles	± 1 %	$\frac{\Delta V_{1-2}}{V_{1-3}} \leq \pm 2\%$
Rotational Life (Electrical and Mechanical)	100 cycles - rated power	± 3 %	
Shock	MIL STD 202 Method 213/1 100 g - 6 ms 3 successive shocks in 3 directions	± 1 %	$\frac{\Delta V_{1-2}}{V_{1-3}} \leq \pm 1\%$
Vibration	MIL STD 202 Method 204/D 20 g - 12 hours	± 1 %	$\frac{\Delta V_{1-2}}{V_{1-3}} \leq \pm 1\%$



Surface Mount Miniature Trimmers
Multiturn Cermet Sealed

Vishay Sfernice

STANDARD RESISTANCE ELEMENT DATA				
STANDARD RESISTANCE VALUES	LINEAR LAW			T.C. - 55°C + 125°C ppm/°C
	MAX. POWER AT 85°C	MAX. WORKING VOLTAGE	MAX. CUR. THROUGH ELEMENT	
Ω	W	V	mA	
10	0.25	1.58	158	0 + 200
20		2.23	112	
50		3.53	77	
100	↓	5	50	± 100
200		7.07	35	
500		11.2	22	
1k		15.8	15.8	
2k		22.3	11.2	
5k		35.3	7.1	
10k		50	5	
20k		70.7	3.5	
50k		112	2.2	
100k		158	1.6	
200k	0.2	200	1	
500k	0.08	200	0.4	
1M	0.04	200	0.2	

MARKING

VISHAY trademark, ohmic value, manufacturing date.

The ohmic value is indicated by a 3 figure code, the first two digits are significant figures, the third one is the multiplier.

Example: 100 = 10Ω
101 = 100Ω
102 = 1000Ω
503 = 50000Ω

SOLDERING RECOMMENDATIONS

Vapor phase: 215°C /20 to 40 seconds.

Reflow: 230°C/20 seconds

Do not exceed peak 260°C

PACKAGING

In bulk (plastic box of 50 pieces).

On tape and reel on request, by 500 pieces for Z version, or 250 pieces for Y version.

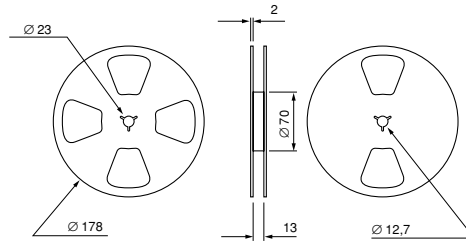

Version Y

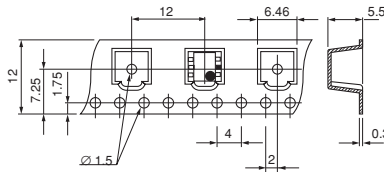

Version Z

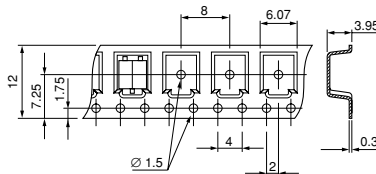

ORDERING INFORMATION

TSM4	YL	500KΩ	± 10%	BO50
SERIES	STYLE	OHMIC VALUE	TOLERANCE	PACKAGING

On request Version Z: code TR500
Version Y: code TR250
BO50