

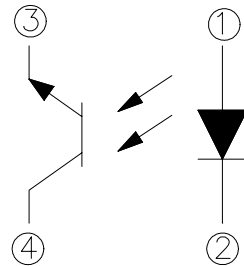

■ Package Dimensions :

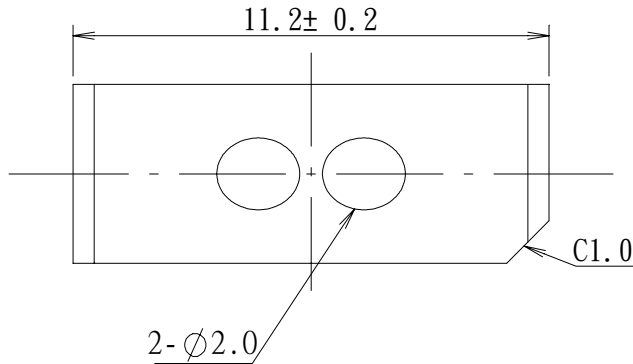

- ①: Anode
- ②: Cathode
- ③: Emitter
- ④: Collector

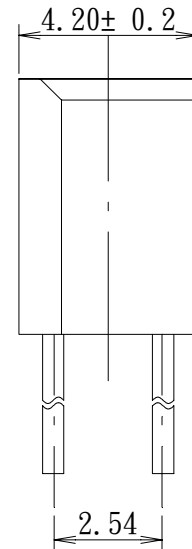
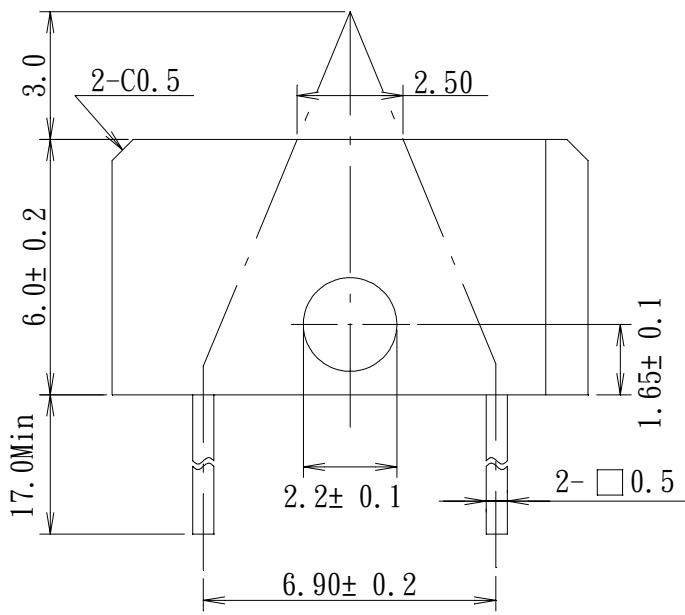

Office: NO 25,Lane.76, Chung Yang Rd., Sec.3, Tucheng, Taipei 236, Taiwan, R.O.C.

TEL: 886-2-2267-2000,2267-9936(22Lines)

FAX: 886-2-2267-6189

http: //www.everlight.com



## ■Description

The **ITR9904** consists of an infrared emitting diode and an NPN silicon phototransistor, encased oblique angle ( $45^\circ$ ) on converging optical axis in a black thermoplastic housing. The phototransistor receives radiation from the IRED only. This is the normal situation. For additional component information, please refer to **IR1254-R8** and **PT1254-6B**.

## ■Features

ITR:

- Fast response time
- High analytic
- Cut-off visible wavelength  $\lambda_p=980\text{nm}$
- High sensitivity

## ■Applications

- Copier
- Scanner
- Non-contact Switching
- For Direct PC Board



■ Absolute Maximum Ratings (Ta=25°C)

Parameter		Symbol	Rated	Unit
Input	Power Dissipation	Pd	100	mW
	Reverse Voltage	V <sub>R</sub>	5	V
	Forward Current	I <sub>F</sub>	50	mA
	Peak Forward Current (*1)	I <sub>FP</sub>	1.0	A
Output	Collector Power Dissipation	PC	75	mW
	Collector Current	I <sub>C</sub>	20	mA
	Collector-Emitter Voltage	V <sub>CEO</sub>	30	V
	Emitter-Collector Voltage	V <sub>ECO</sub>	5	V
Operating Temperature		Topr	-25~+85	°C
Storage Temperature		Tstg	-40~+85	°C
Soldering Temperature (*2)		Tsol	260	°C

(\*1) tw=100 μsec. , Duty cycle=1% (\*2) t=5 Sec

■ Electrical Characteristics (Ta=25°C)

Parameter		Symbol	Min.	Typ.	Max.	Unit	Conditions
Input	Forward Voltage	V <sub>F1</sub>	-	1.2	1.5	V	I <sub>F</sub> =20mA
		V <sub>F2</sub>	-	1.4	1.85	V	I <sub>F</sub> =100mA
		V <sub>F3</sub>	-	2.6	4.0	V	I <sub>F</sub> =1A
	Reverse Current	I <sub>R</sub>	-	-	10	μA	V <sub>R</sub> =5V
	Peak Wavelength	λ <sub>P</sub>	-	940	-	nm	-
	View Angle	2€1/2	-	35	-	Deg	I <sub>F</sub> =20mA
Output	Dark Current	I <sub>CEO</sub>	-	-	100	nA	V <sub>CE</sub> =20V Ee=0mW/cm <sup>2</sup>
	C-E Saturation Voltage	V <sub>CE(sat)</sub>	-	-	0.4	V	I <sub>C</sub> =2mA I <sub>B</sub> =0.1mA
Collector Current		I <sub>C(ON)A</sub>	100	-	300	μA	V <sub>CE</sub> =5V I <sub>F</sub> =20mA
		I <sub>C(ON)B</sub>	200	-	600		
		I <sub>C(ON)C</sub>	400	-	1200		
Speed	Rise time	t <sub>R</sub>	-	15	-	μsec	V <sub>CE</sub> =2V I <sub>C</sub> =1mA R <sub>L</sub> =1KΩ
	Fall time	t <sub>F</sub>	-	15	-	μsec	



■ Typical Characteristics For IR

Fig. 1 Forward Current vs. Ambient Temperature

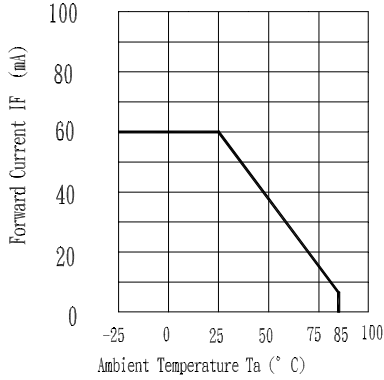

Fig. 2 Spectral Distribution

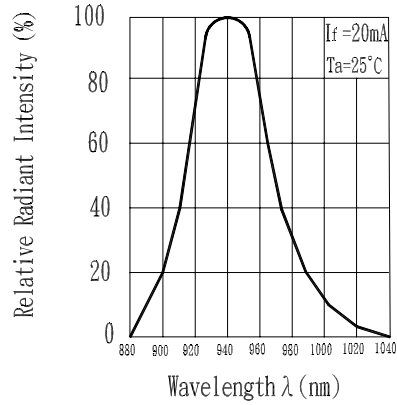

Fig. 3 Peak Emission Wavelength vs. Ambient Temperature

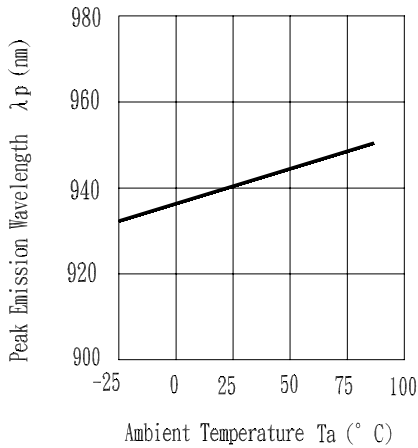

Fig. 4 Forward Current vs. Forward Voltage

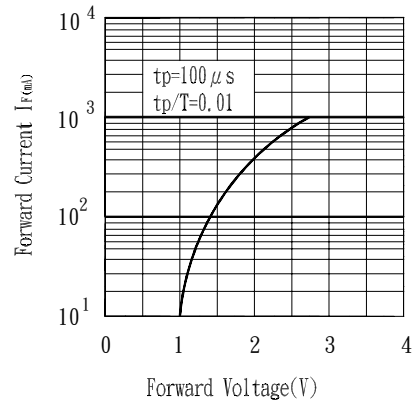

Fig. 5 Relative Intensity vs. Forward Current

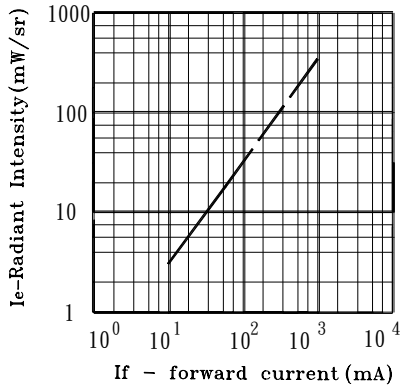
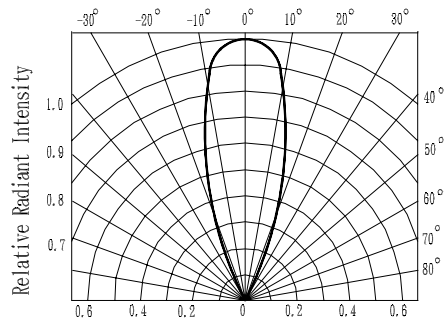

Fig. 6 Relative Radiant Intensity vs. Angular Displacement





### Typical Characteristics For PT

Fig.1 Collector Power Dissipation vs. Ambient Temperature

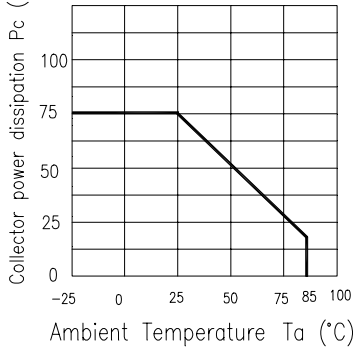

Fig.2 Collector Dark Current vs. Ambient Temperature

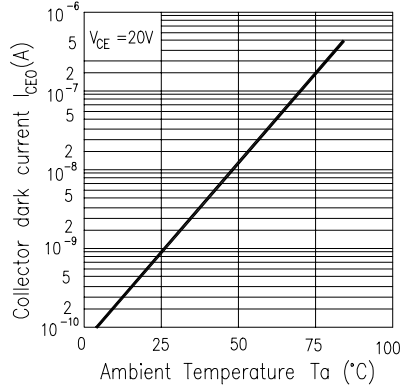

Fig. 3 Relative Collector Current vs. Ambient Temperature

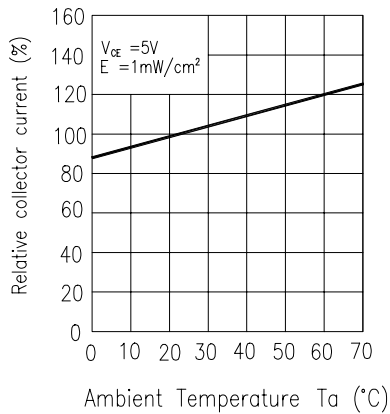

Fig.4 Collector Current vs. Irradiance

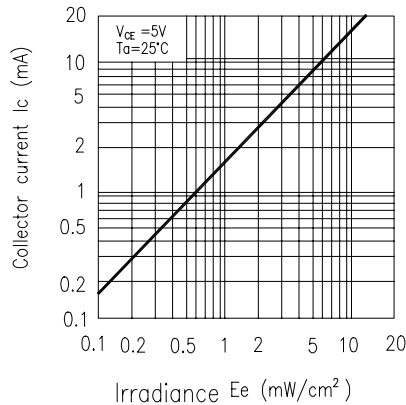

Fig.5 Spectral Sensitivity

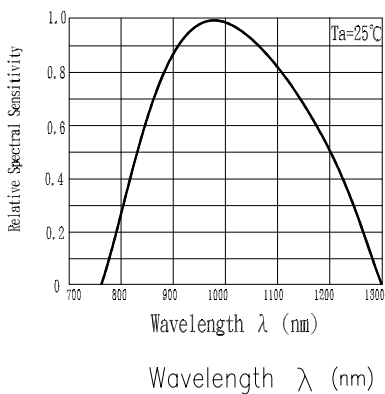
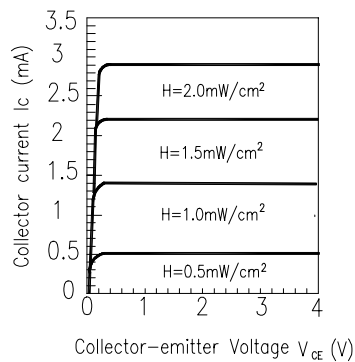

Fig.6 Collector Current vs. Collector-emitter Voltage





■ Reliability Test Item And Condition

The reliability of products shall be satisfied with items listed below.

Confidence level : 90% LTPD : 10%

Items	Purpose & Condition	Failure Judgement Criteria	Samples(n)
			Defect (c)
Temperature Cycle	Evaluates product's ability to withstand exposure to high temperature, low temperature, and temperature variation between two limit temperature. Standard test Condition: $85^{\circ}\text{C} \sim 25^{\circ}\text{C} \sim -55^{\circ}\text{C} \sim 25^{\circ}\text{C}$ $\downarrow \quad \downarrow \quad \downarrow \quad \downarrow$ 30min 5min 30min 5min 50 cycle	$I_R \geq U \times 2$ $I_{c(on)} \leq L \times 0.8$ $V_F \geq U \times 1.2$  U : Upper specification limit	n = 22 , c = 0
Thermal Shock	Evaluates product's ability to withstand rapid temperature change Standard test Condition: 85°C ~ -55°C 5min(10sec)5min 50cycle	L : Lower specification limit	n = 22 , c = 0
High Storage	Evaluates product's ability to withstand prolonged storage at high temperature Standard test Condition: Temperature : 100 °C Time : 1000hrs		n = 22 , c = 0
Low Storage	Evaluates product's ability to withstand prolonged storage at low temperature Standard test Condition: Temperature : -55 °C Time : 1000hrs		n = 22 , c = 0



# EVERLIGHT ELECTRONICS CO, LTD.

Device Number: DRX-904-101 REV: 1.0

MODEL NO: ITR9904

Ecn: \_\_\_\_\_ Page: 7/8

Items	Purpose & Condition	Failure Judgement Criteria	Samples(n)
			Defective(c)
Operating Life	Evaluates product's endurance to prolonged electrical or temperature stresses. Standard test Condition: $V_{CE}=5V$ $I_F=20mA$ Time : 1000hrs	$I_R \geq U \times 2$ $I_{c(on)} \leq L \times 0.8$ $V_F \geq U \times 1.2$	n = 22 , c = 0
High Temperature High Humidity	Evaluates product's ability to withstand prolonged storage at high temperature and high humidity. Standard test Condition: Temperature: 85°C Relative humidity: 85% Time : 1000hrs	U : Upper specification limit  L : Lower specification limit	n = 22 , c = 0
Soldering Heat	Evaluates product's ability to withstand soldering heat Standard test conditions Solder temperature : 260±5°C Solder time : 10 seconds		n = 22 , c = 0

## ■ Supplement

### (1) Chip

Type	Material	Peak Wavelength
IR	GaAlAs	940nm
PT	Silicon	980nm

### (2) Material

Type	Lead frame	Wire	Package	Holder
ITR	SPCC	Gold	Epoxy	NORYL



### ■ Packing Specification

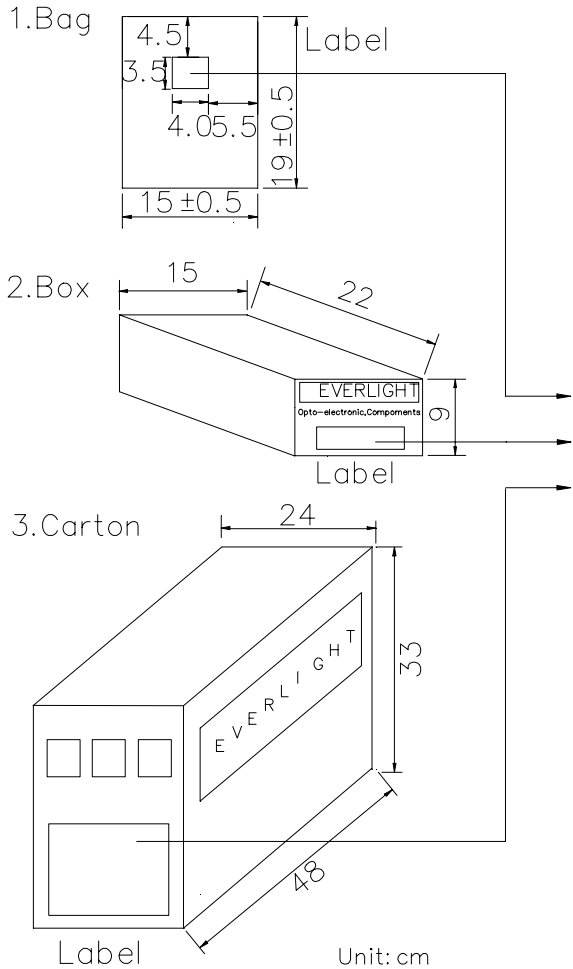

- CPN: Customer's product number**
- P/N: Product number**
- QTY: Packing quantity**
- CAT: Ranks**
- HUE: Peak wavelength**
- REF: Reference**
- LOT NO: Lot number**
- MADE IN TAIWAN: Production place**

### ■ Packing Quantity Specification

- 1. 200Pcs/1Bag
- 2. 6Bags/1Box
- 3. 10Boxes/1Carton