

Description

IR3101 is a gate driver IC integrated half bridge FredFET designed for sub 250W (heat-sink-less) motor drive applications. The sleek and compact single-in-line package is optimized for electronic motor control in appliance applications such as fans and compressors for refrigerators. The IR3101 offers an extremely compact, high performance half-bridge inverter, in a single isolated package for a very simple design for two-phase and three-phase motor drivers.

Proprietary HVIC and latch immune CMOS technologies, along with the HEXFET® power FredFET® technology (HEXFET® with ultra-fast recovery body diode characteristics), enable efficient and rugged single package construction. Propagation delays for the high and low side power FredFETs are matched thanks to the advance IC technology.

Features

- Output power FredFets in half-bridge configuration
- High side gate drive designed for bootstrap operation
- Bootstrap diode integrated into package.
- Lower power level-shifting circuit
- Lower di/dt gate drive for better noise immunity
- Excellent latch immunity on all inputs and outputs
- ESD protection on all leads
- Isolation 1500 V_{RMS} min

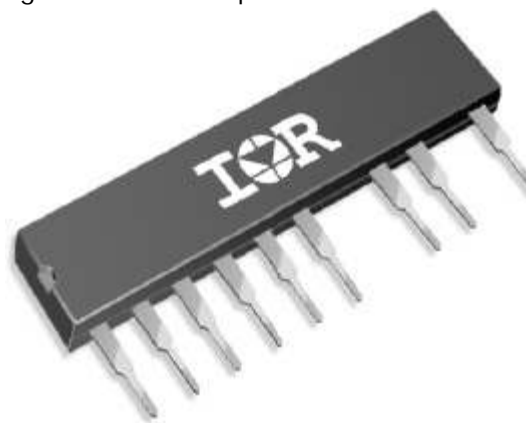

Absolute Maximum Ratings

Absolute maximum ratings indicate sustained limits beyond which damage to the device may occur. All voltage parameters are absolute voltages referenced to COM. The thermal resistance and power dissipation are measured under board mounted and still air conditions.

Parameters	Description	Max. Values	Units	
V _{DD}	High voltage supply	500	V	
V _B	High side floating supply	V _o + 25	V	
P _D	Package power dissipation @ T _C ≤ 80°C (per die)	5.8	W	
R _{thJC}	Thermal resistance, junction to case	12	°C/W	
R _{thJA}	Thermal resistance, junction to ambient (note 1)	85	°C/W	
V _{ISO}	Isolation Voltage (1 min)	1500	V _{RMS}	
T _J	Junction temperature (Power Mosfet)	-40 to +150	°C	
T _S	Storage temperature	-40 to +150	°C	
T _L	Lead temperature (soldering, 10 seconds)	300	°C	
I _o	Maximum current rating (note 2)	1.6	A	
I _o	Continuous output current (V _{IN} =5V, V _{CC} =15V)	(T _C = 100°C)	1.3	A
		(T _C = 25°C)	2	A

Note 1: under normal operational conditions: both power devices working, no heatsink

Note 2: see figure 4, f_{PWM}=20kHz

Internal Electrical Schematic - IR3101

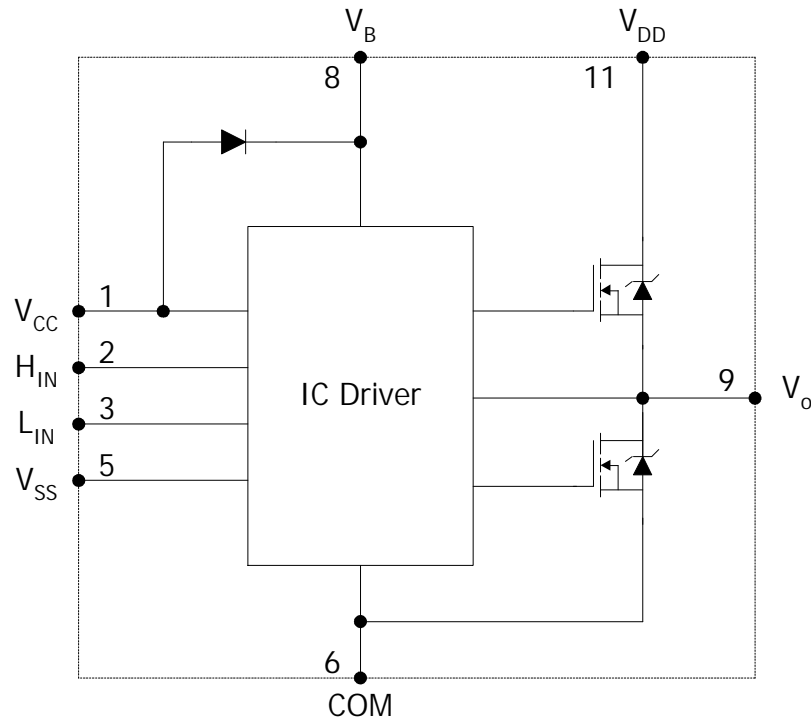

Figure 1: Internal connections

Recommended Operating Conditions

For proper operation, the device should be used within the recommended conditions.

Symbol	Definition	Min.	Max.	Units
V_B	High side floating supply absolute voltage	$V_O + 10$	$V_O + 20V$	V
V_{DD}	High voltage supply	-	450	V
V_{CC}	Low side and logic fixed supply voltage	10	20	V
V_{IN}	Logic input voltage	V_{SS}	V_{CC}	V
V_{SS}	Logic ground	-5	5	V

Note 3: Care should be taken to avoid switching condition where the V_O node flies inductively below COM by more than 5V

MOSFET Characteristics

V_{BIAS} (V_{CC} , V_B) = 15V and T_A = 25°C unless otherwise specified. The V_{DD} parameter is referenced to COM.

Symbol	Definition	Min.	Typ	Max.	Units	Conditions
$V_{(BR)DSS}$	Drain-to-Source breakdown voltage	500	-	-	V	$V_{IN}=0V$, $I_D=250\mu A$
I_{DSS}	Drain-to-Source leakage current	-	-	50	μA	$V_{DS}=500V$, $V_{IN}=0V$
$R_{DS(on)}$	Static drain-to-source on resistance	-	0.8	1.0	Ω	$I_D = 1.5A$
V_{SD}	Diode forward voltage	-	0.82	0.9	V	$I_D = 1.5A$, $V_{IN}=0V$
$R_{DS(on)}$	Static drain-to-source on resistance	-	1.7	2.0	Ω	$I_D = 1.5A$, $T_J=125^\circ C$
V_{SD}	Diode forward voltage	-	0.70	0.79	V	$I_D = 1.5A$, $V_{IN}=0V$, $T_J=125^\circ C$
E_{ON}	Turn-On energy losses	-	100	135	μJ	$I_F = 1.5A$ $V_{CC} = 300V$ $di/dt = 200A/\mu s$
E_{OFF}	Turn-Off energy losses	-	5	10	μJ	
E_{REC}	Body-Diode reverse recovery Losses	-	10	20	μJ	
t_{RR}	Reverse recovery time	-	105	180	ns	
E_{ON}	Turn-On energy losses	-	150	205	μJ	$T_J=125^\circ C$ $I_F = 1.5A$ $V_{CC} = 300V$ $di/dt = 200A/\mu s$
E_{OFF}	Turn-Off energy losses	-	10	17	μJ	
E_{REC}	Body-Diode reverse recovery Losses	-	15	35	μJ	
t_{RR}	Reverse recovery time	-	130	230	ns	
C_{OSS}	Output capacitance	-	-	100	pF	$V_{IN}=0V$, $V_{DD}=30V$, $f=1MHz$

Driver IC Characteristic

Symbol	Definition	Min.	Typ.	Max.	Units	Conditions
V_{CCUV+}	V_{CC} supply undervoltage positive going threshold	8.0	8.9	9.8	V	
V_{CCUV-}	V_{CC} supply undervoltage negative going threshold	7.4	8.2	9.0	V	
V_{CCUVH}	V_{CC} supply undervoltage lockout hysteresis	0.3	0.7	-	V	
V_{BSUV+}	V_{BS} supply undervoltage positive going threshold	8.0	8.9	9.8	V	
V_{BSUV-}	V_{BS} supply undervoltage negative going threshold	7.4	8.2	9.0	V	
V_{BSUVH}	V_{BS} supply undervoltage lockout hysteresis	0.3	0.7	-	V	
V_{IH}	Logic "1" input voltage for H _{IN} & L _{IN}	2.9	-	-	V	$V_{CC}=10V$ to $20V$
V_{IL}	Logic "0" input voltage for H _{IN} & L _{IN}	-	-	0.8	V	$V_{CC}=10V$ to $20V$
I_{IN+}	Logic "1" input bias current	-	5	20	μA	$H_{IN}, L_{IN} = 5V$
I_{IN-}	Logic "0" input bias current	-	1	2	μA	$H_{IN}, L_{IN} = 0V$
MT	Delay Matching HS & LS turn on/ turn off	-	0	30	ns	

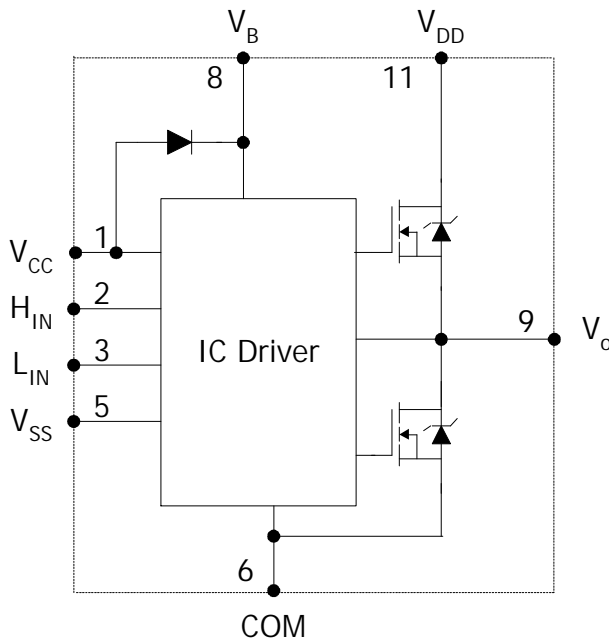

H _{IN}	L _{IN}	V _O
0	1	0
1	0	V_{DD}
1	1	Shoot-Through condition
X	X	X

Figure 2: Driver input/output relation

Module Pin-Out Description

Pin	Symbol	Lead Definitions
1	V_{CC}	Logic and internal gate drive supply
2	H_{IN}	Logic input for high side gate output
3	L_{IN}	Logic input for low side gate output
4		Not Connected
5	V_{SS}	Logic Ground
6	COM	Low side MOSFET gate return
7		Not Connected
8	V_B	High side gate drive floating supply
9	V_O	Half bridge output
10		Not Connected
11	V_{DD}	High voltage supply

Typical Application Connection IR3101

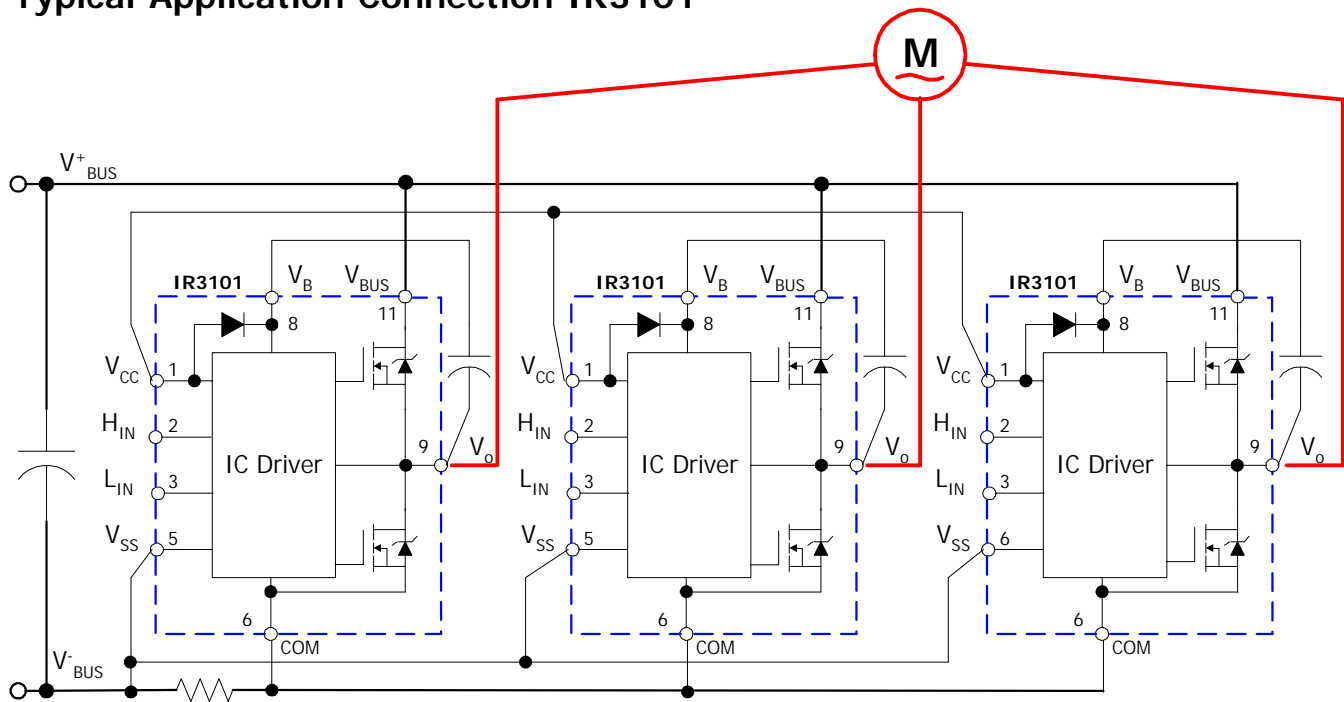

1. Electrolytic bus capacitors should be mounted as close to the module bus terminals as possible to reduce ringing and EMI problems. Additional high frequency ceramic capacitor mounted close to the module pins will further improve performance.
2. In order to provide good decoupling between V_{CC} - V_{SS} and V_B - V_O terminals, a capacitor connected between these terminals is recommended and should be located very close to the module pins. Additional high frequency capacitors, typically $0.1\mu F$, are strongly recommended.
3. Low inductance shunt resistor should be used for phase leg current sensing. Similarly, the length of the traces from the pin to the corresponding shunt resistor should be kept as small as possible.
4. Value of the bootstrap capacitors depends upon the switching frequency. Their selection should be made based on IR design tip DN 98-2a or Figure 8.
5. Application conditions should guarantee minimum dead-time of 200ns

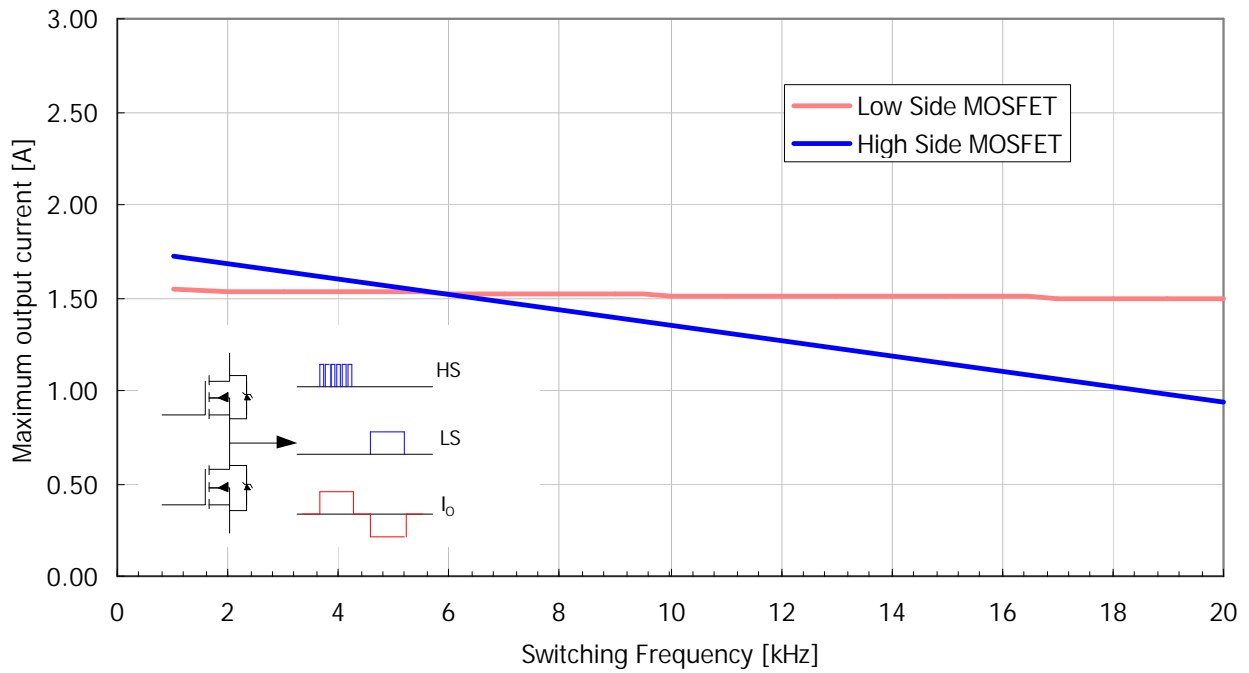

Figure 3: Maximum phase current as function of switching frequency
Trapezoidal modulation, 120° switching, $V_{BUS}=300V$, Duty Cycle=0.8, without heatsink:
 $T_a=55^{\circ}C$, $T_J=150^{\circ}C$

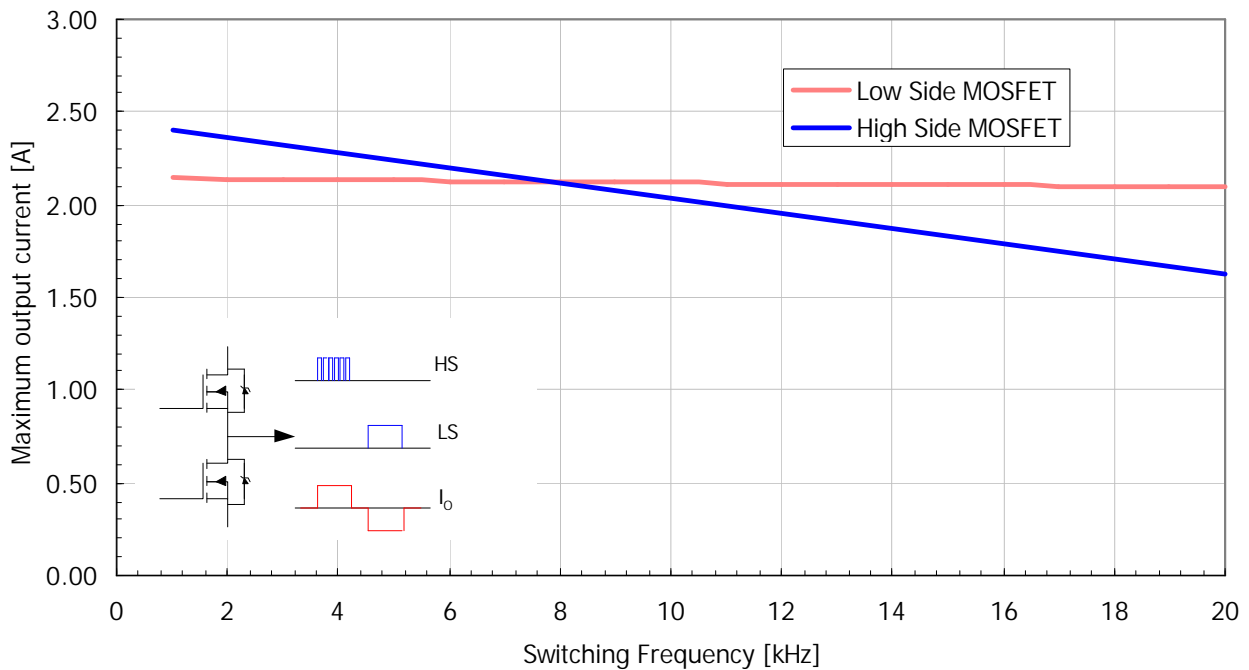

Figure 4: Maximum phase current as function of switching frequency
Trapezoidal modulation, 120° switching, $V_{BUS}=300V$, Duty Cycle=0.8, with heatsink:
 $T_C=100^{\circ}C$, $T_J=125^{\circ}C$

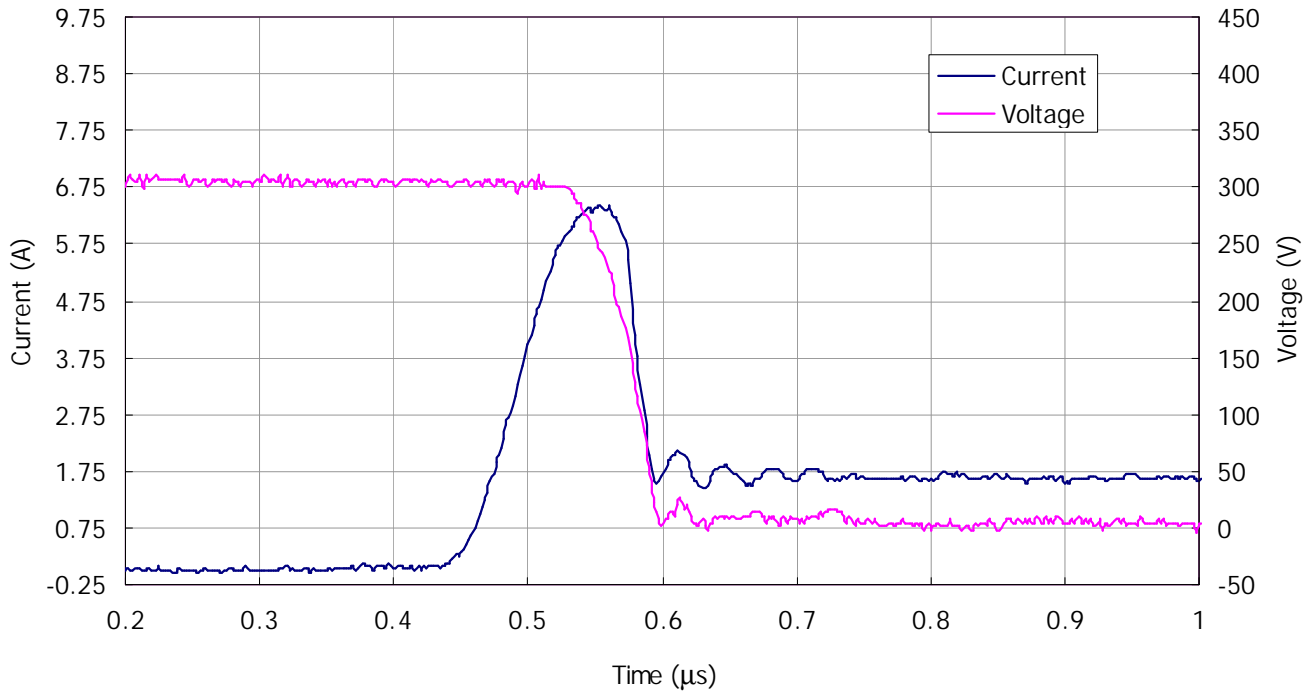

Figure 5. FredFET Turn-on. Typical turn-on waveform @ $T_J=125^\circ\text{C}$, $V_{\text{BUS}}=300\text{V}$

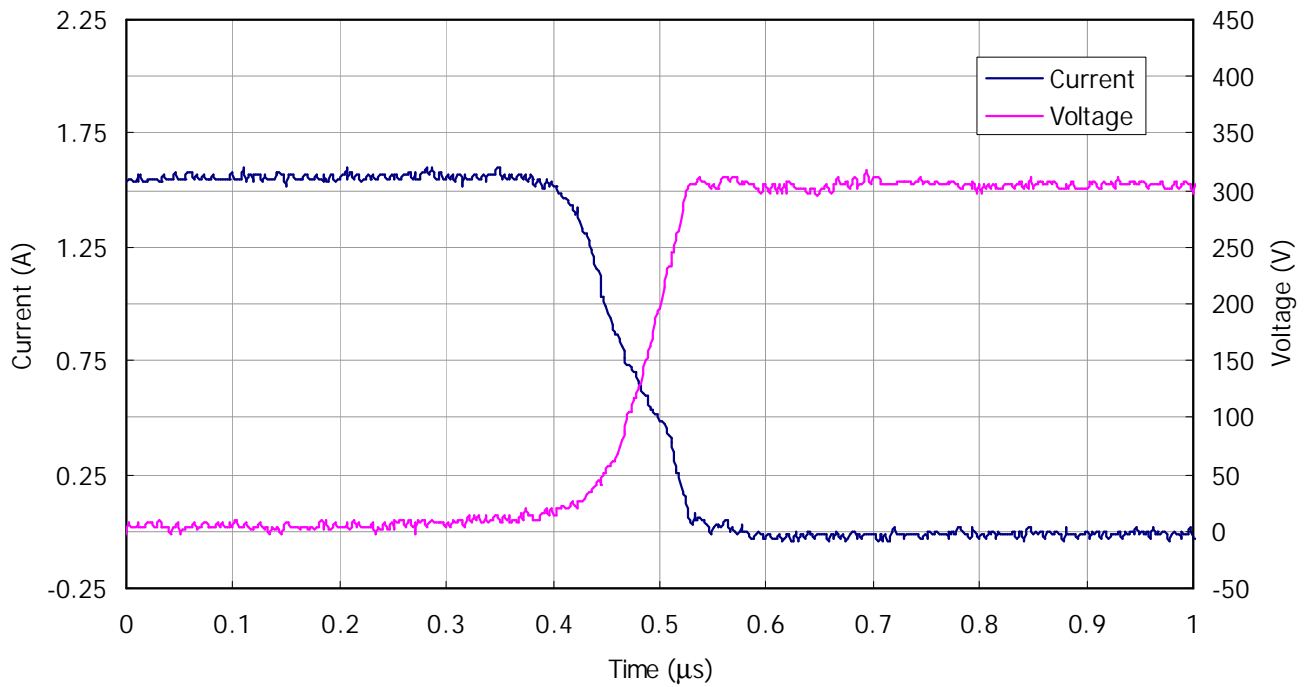

Figure 6. FredFET Turn-off. Typical turn-on waveform @ $T_J=125^\circ\text{C}$, $V_{\text{BUS}}=300\text{V}$

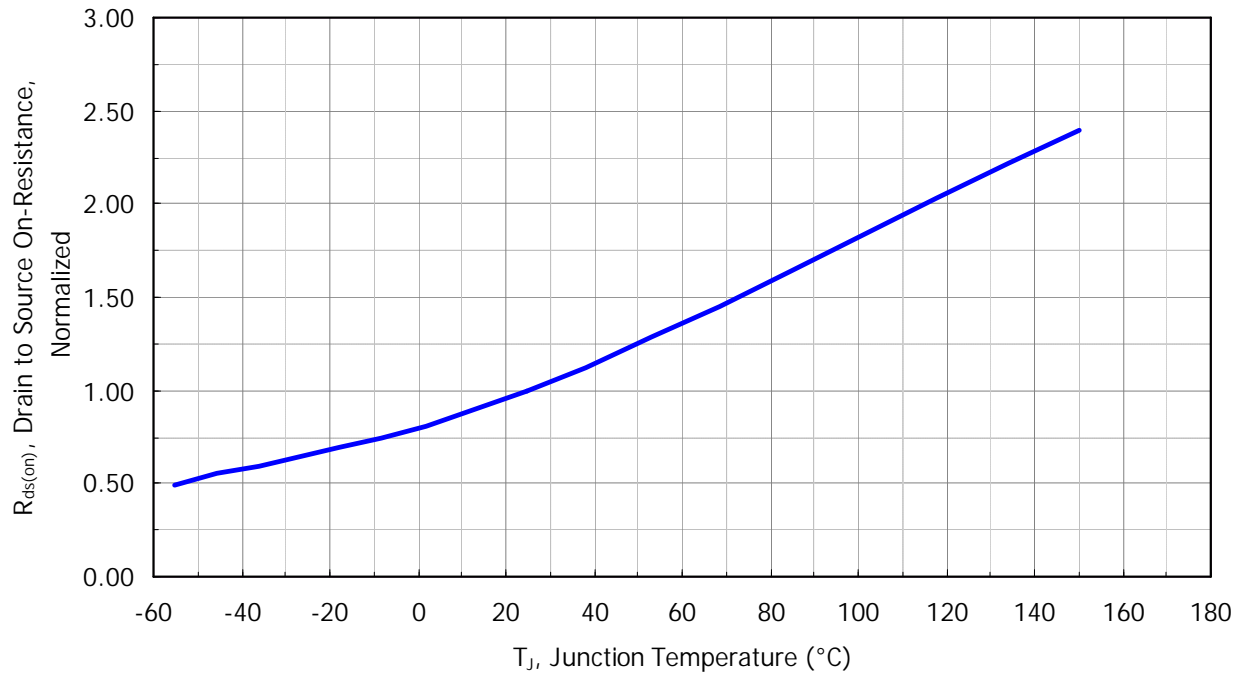

Figure 7: Normalized On-Resistance vs temperature
V_{CC}=10V, I_D=1.5A

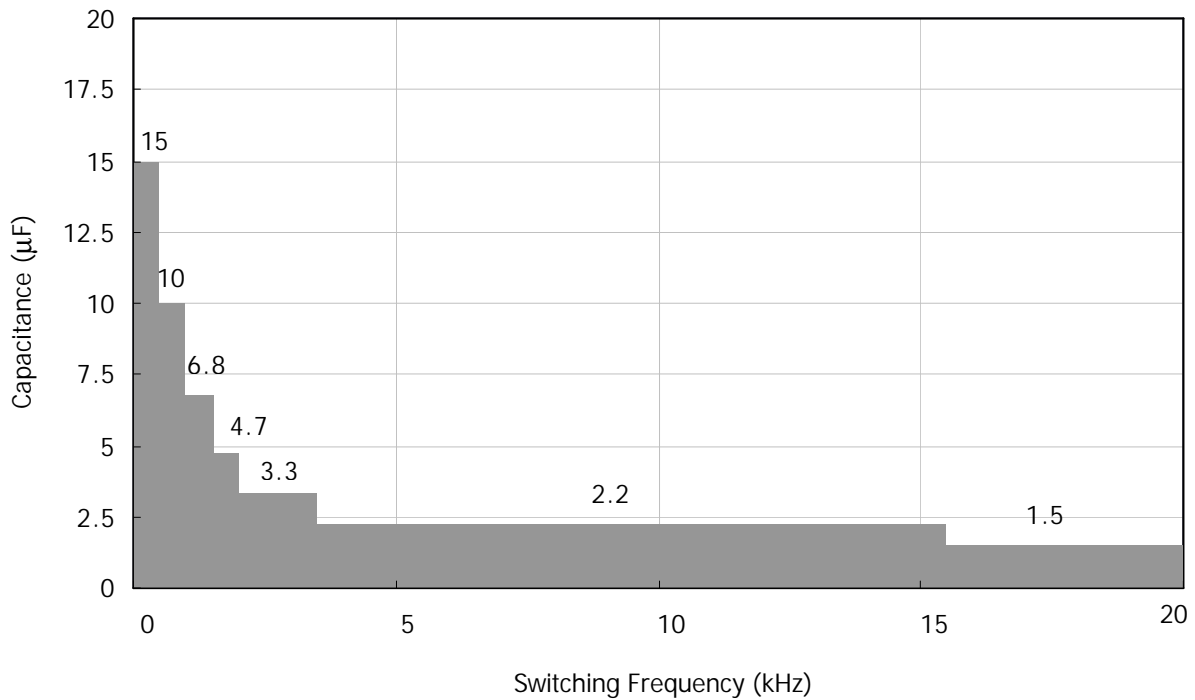

Figure 8: Recommended minimum bootstrap capacitor value vs switching frequency

